

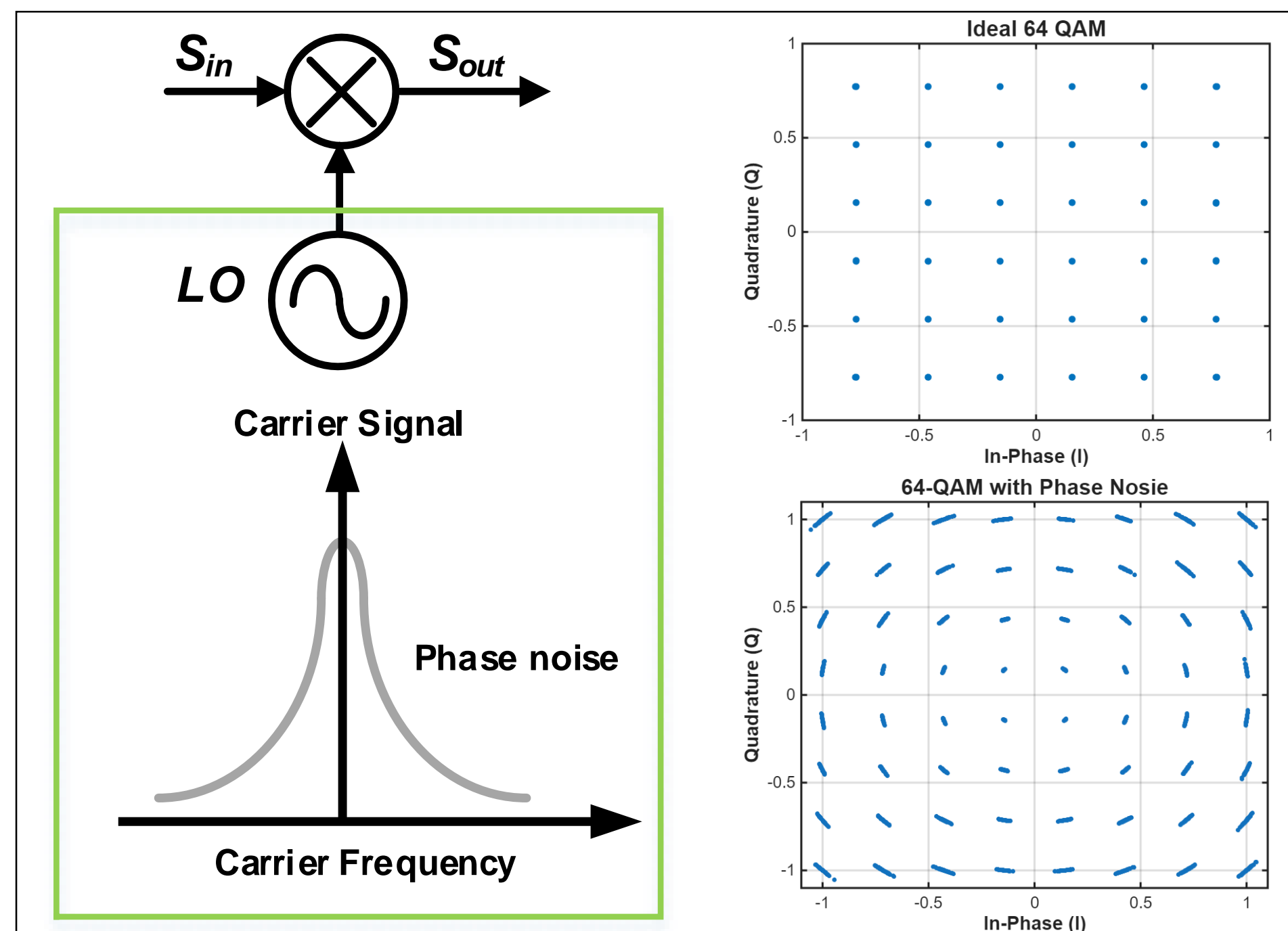

A Wide Tuning Range Dual-Core Class-F VCO With a Switched Inductor

Jiyun Bae, Woojin Lee, Geuntae Kim, and Ockgoo Lee
1Department of Electrical Engineering, Pusan National University

Introduction

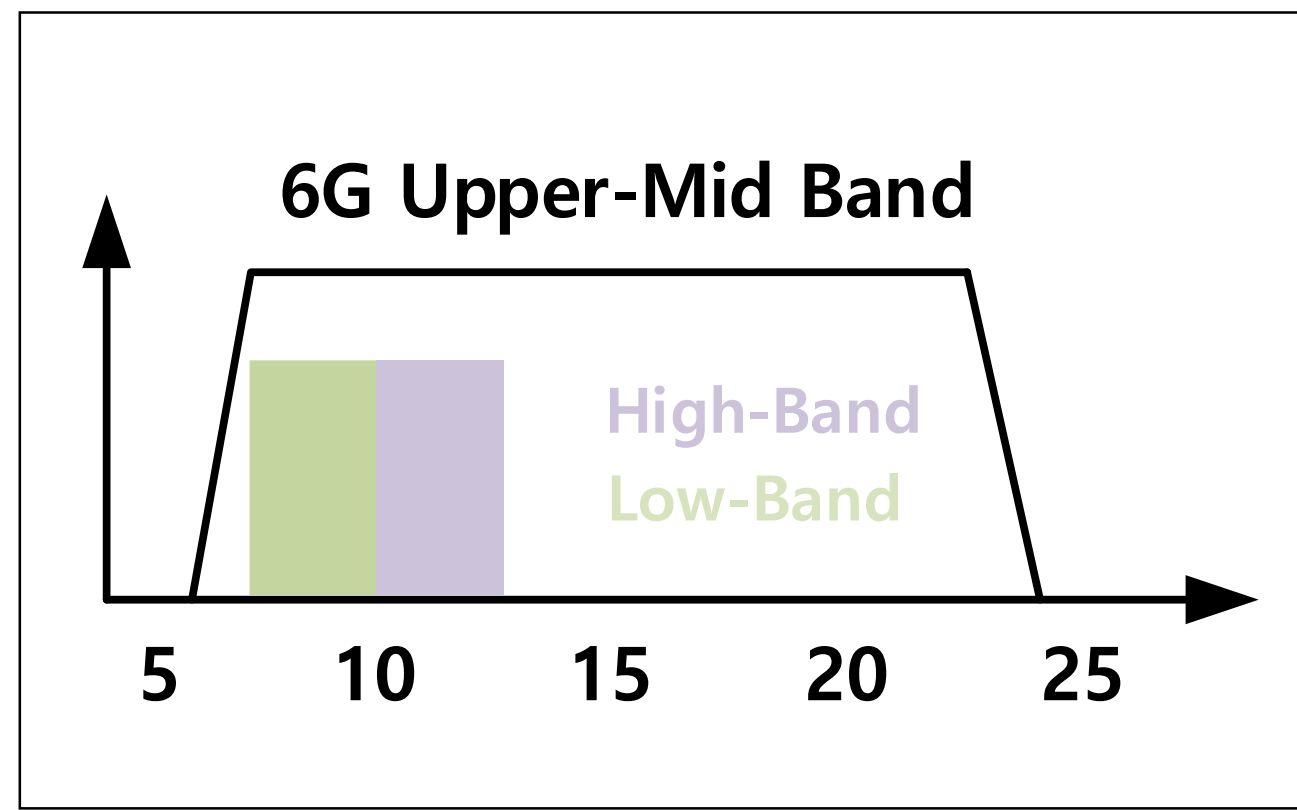

- CMOS VCOs for NR 6G applications
 - ✓ Trade-off between low phase noise and wide tuning range
- Class-F operation
 - ✓ Square voltage waveform improves phase noise by reducing the effective ISF
- Dual-band operation
 - ✓ Dual-band with switch control improves tuning range

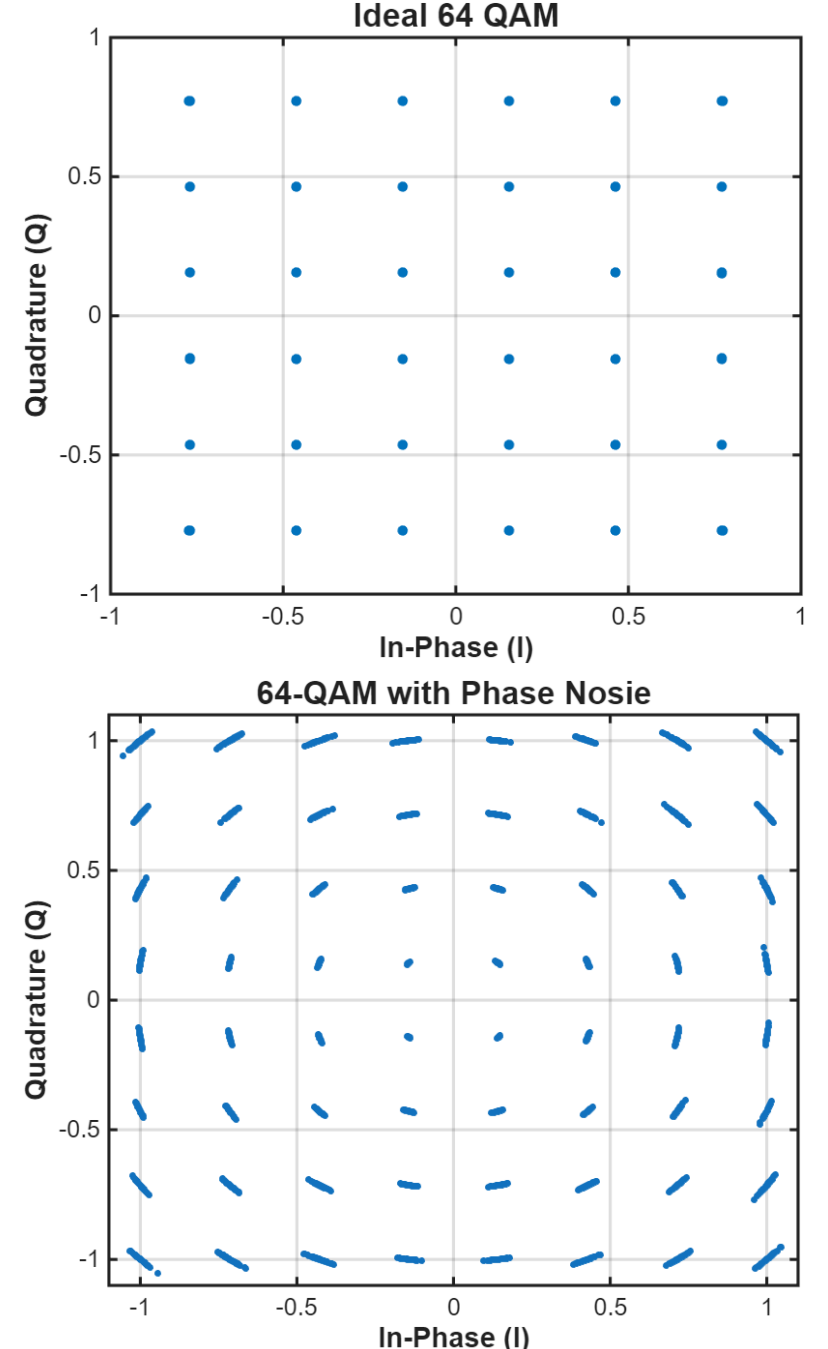

Proposed Dual-Core VCO Using a Switched Inductor

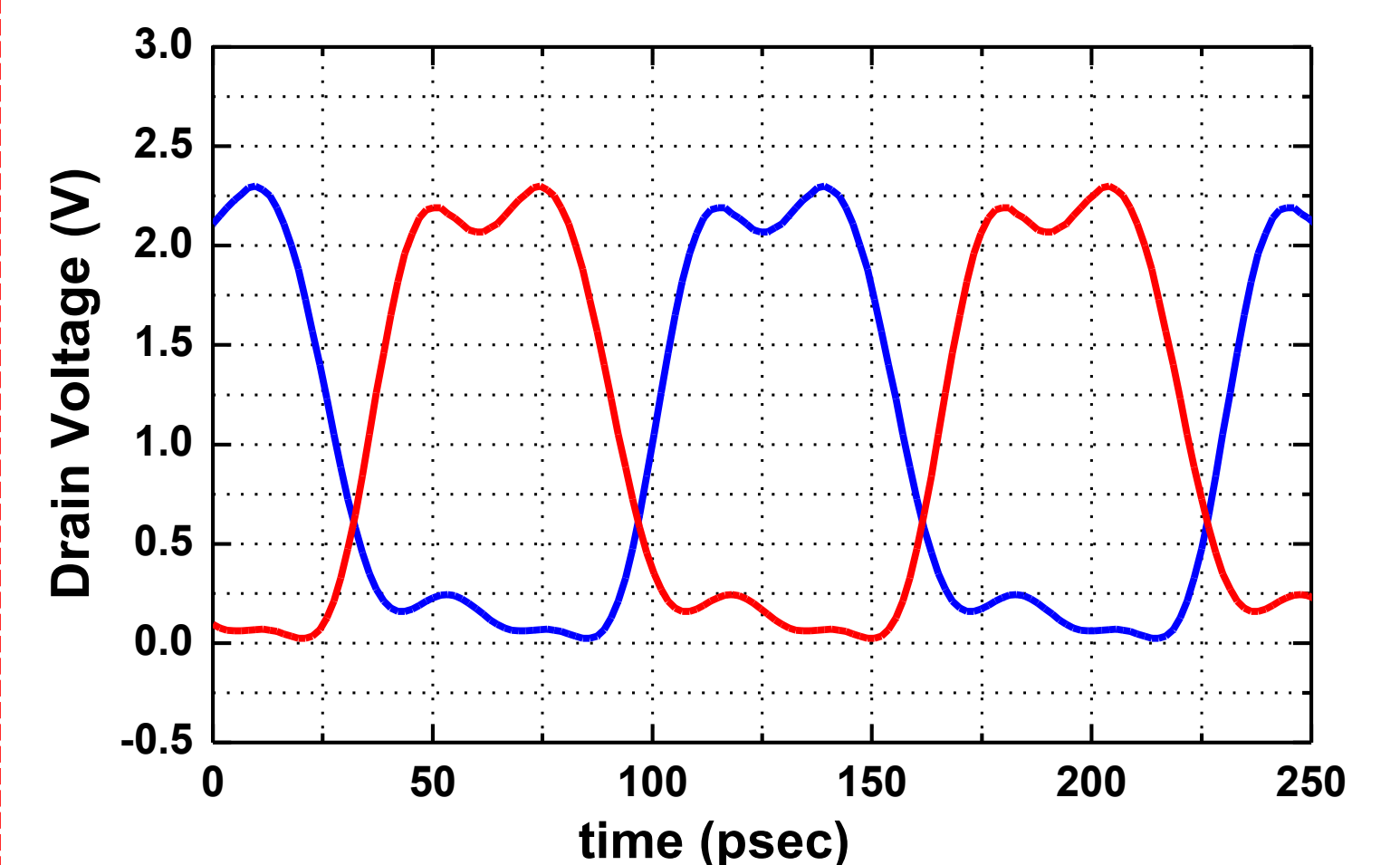
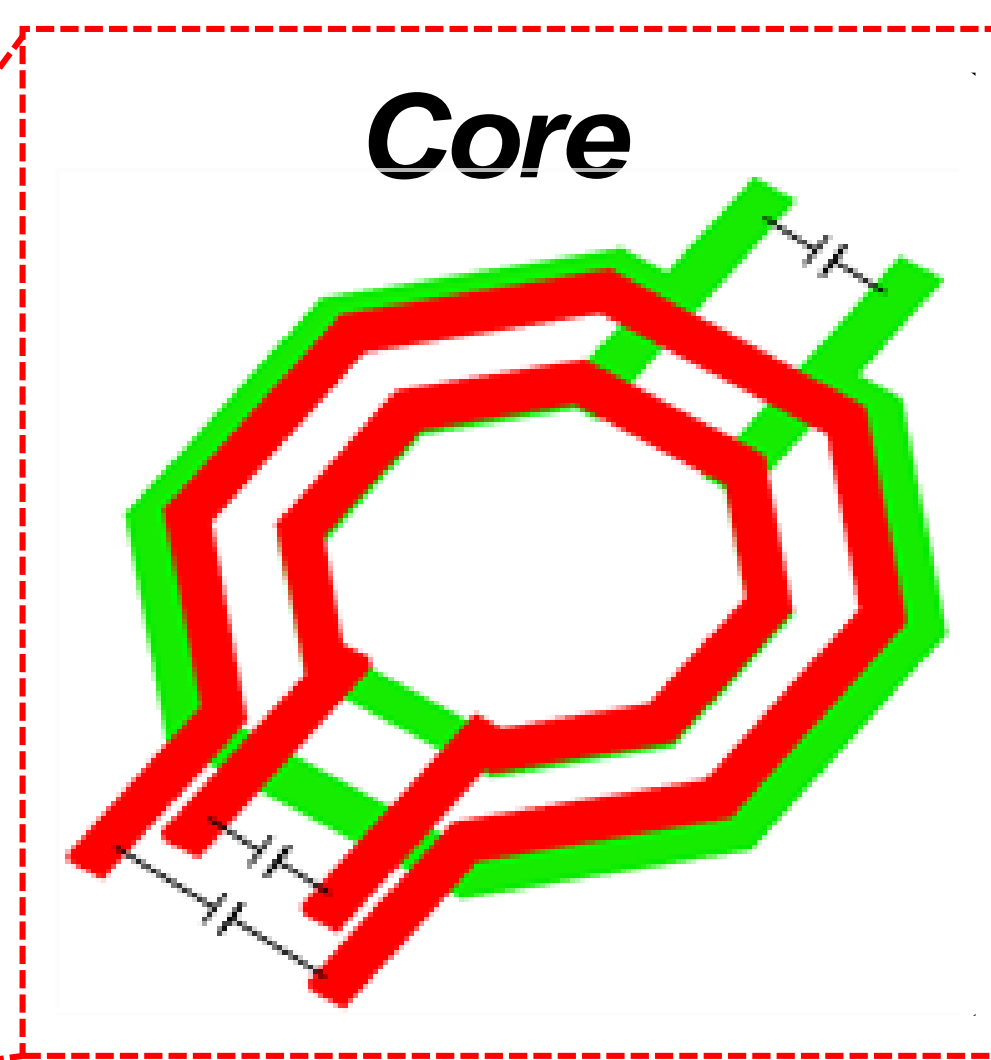
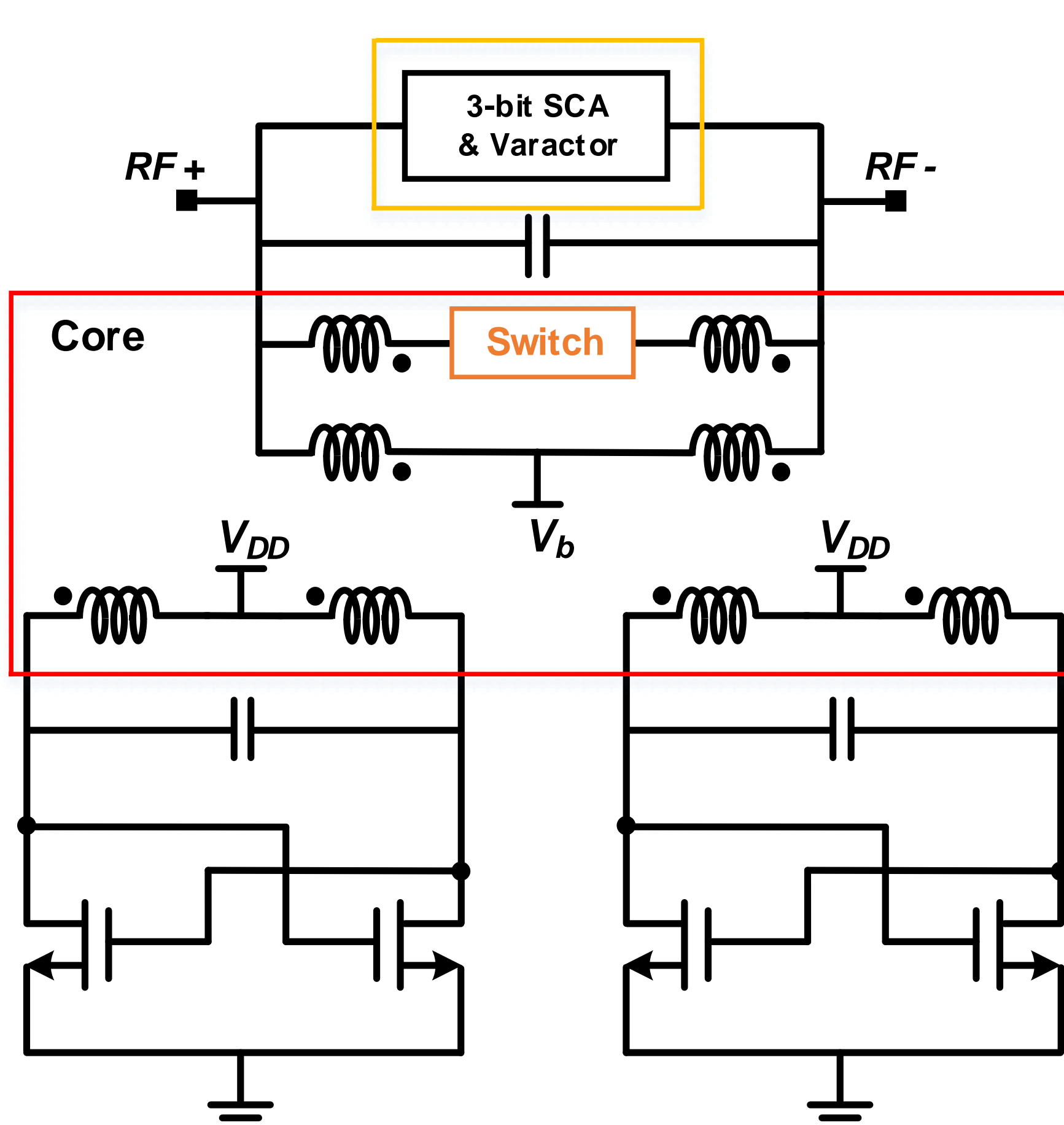
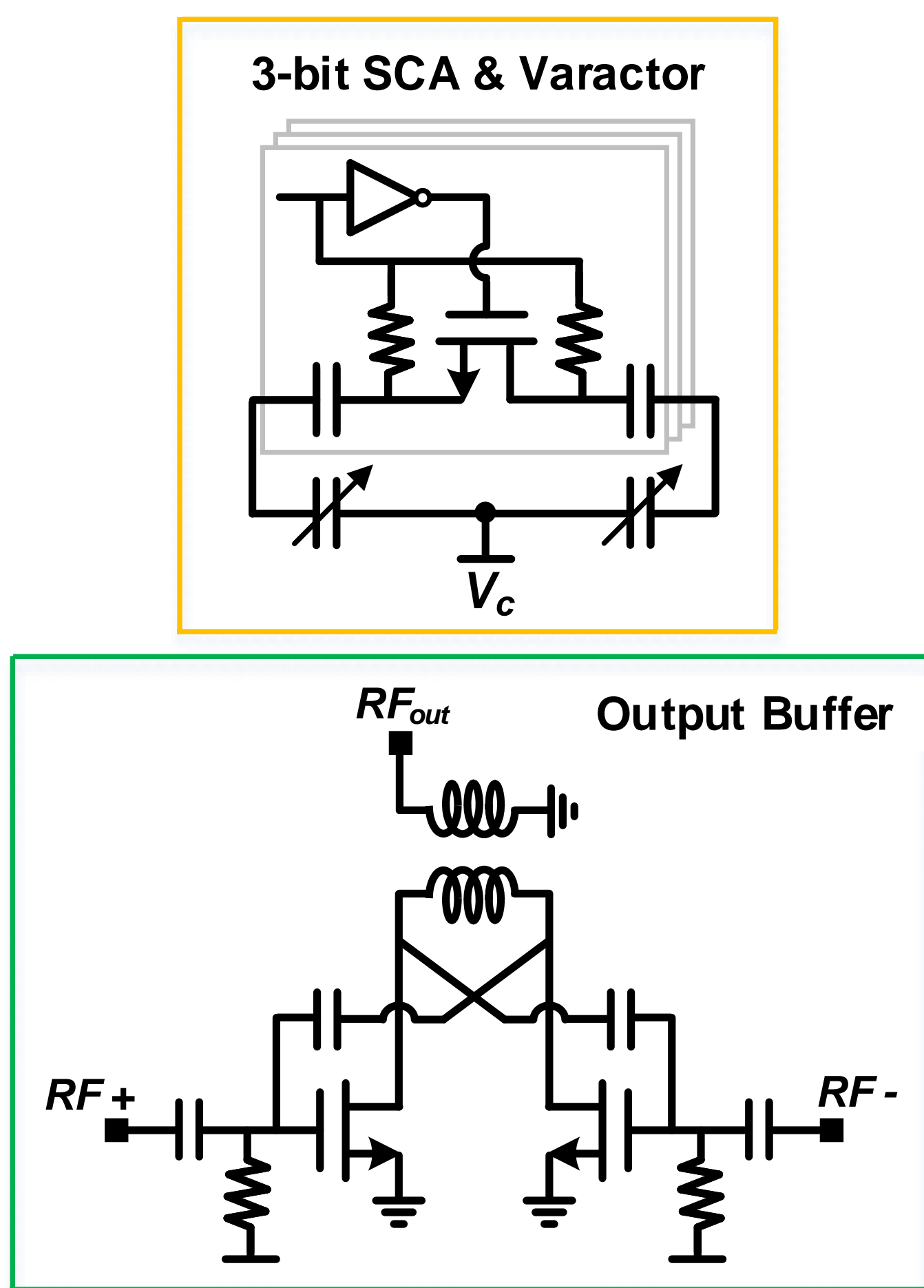

[Proposed core layout and simulated voltage waveform]

[Schematic of the proposed dual-core VCO]

- Switch를 통해 유효 tank inductance 변화
→ Low Band / High Band 동작 구현 → 넓은 tuning range 확보 (50.5%)
- Dual-primary parallel transformer 구조 → compact dual-core 구현
- Class-F의 3rd-harmonic waveform shaping → 전압 peak 평탄화, ISF 감소
→ 낮은 phase noise 확보

Simulated Result

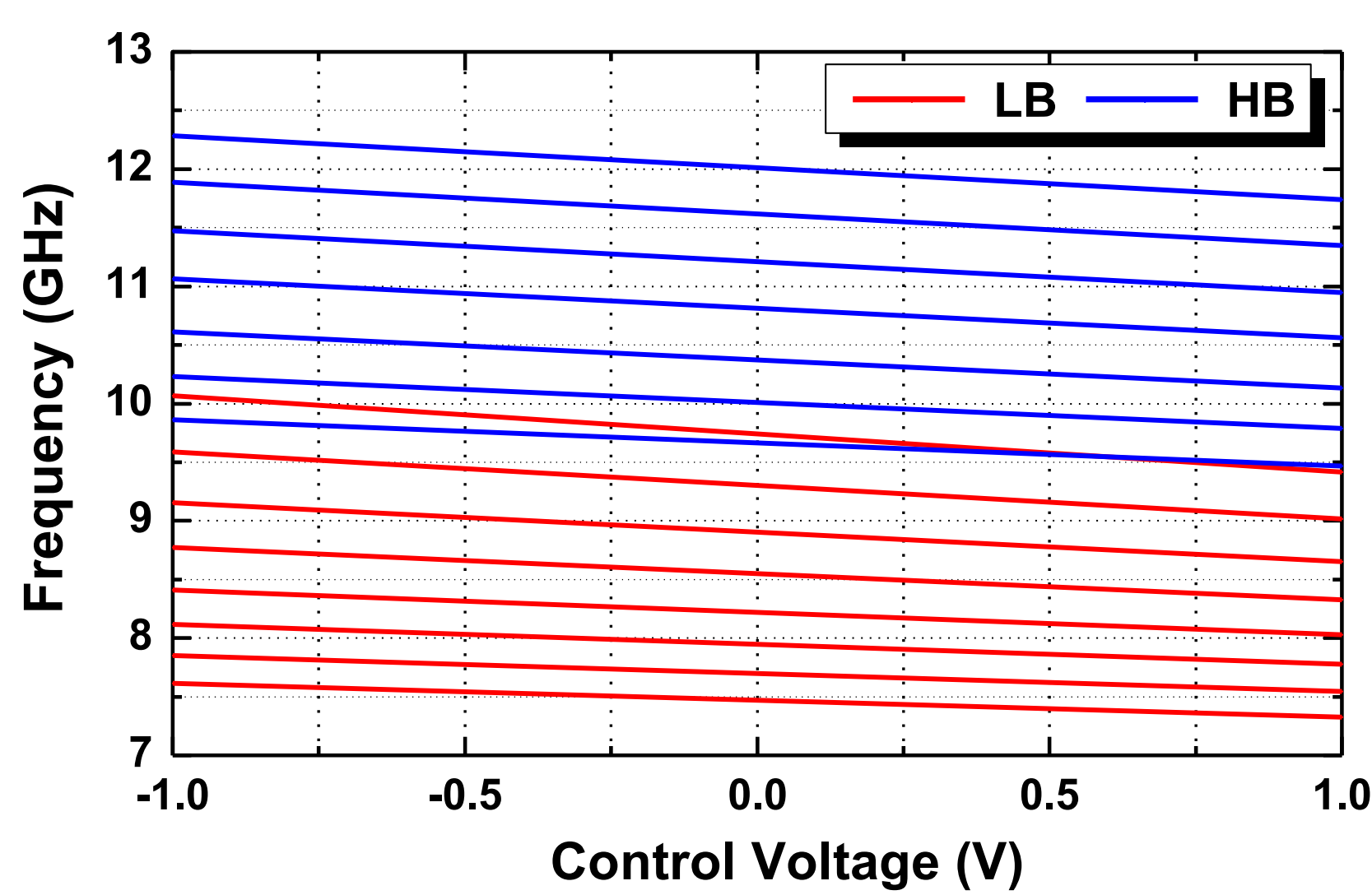

[Frequency tuning range]

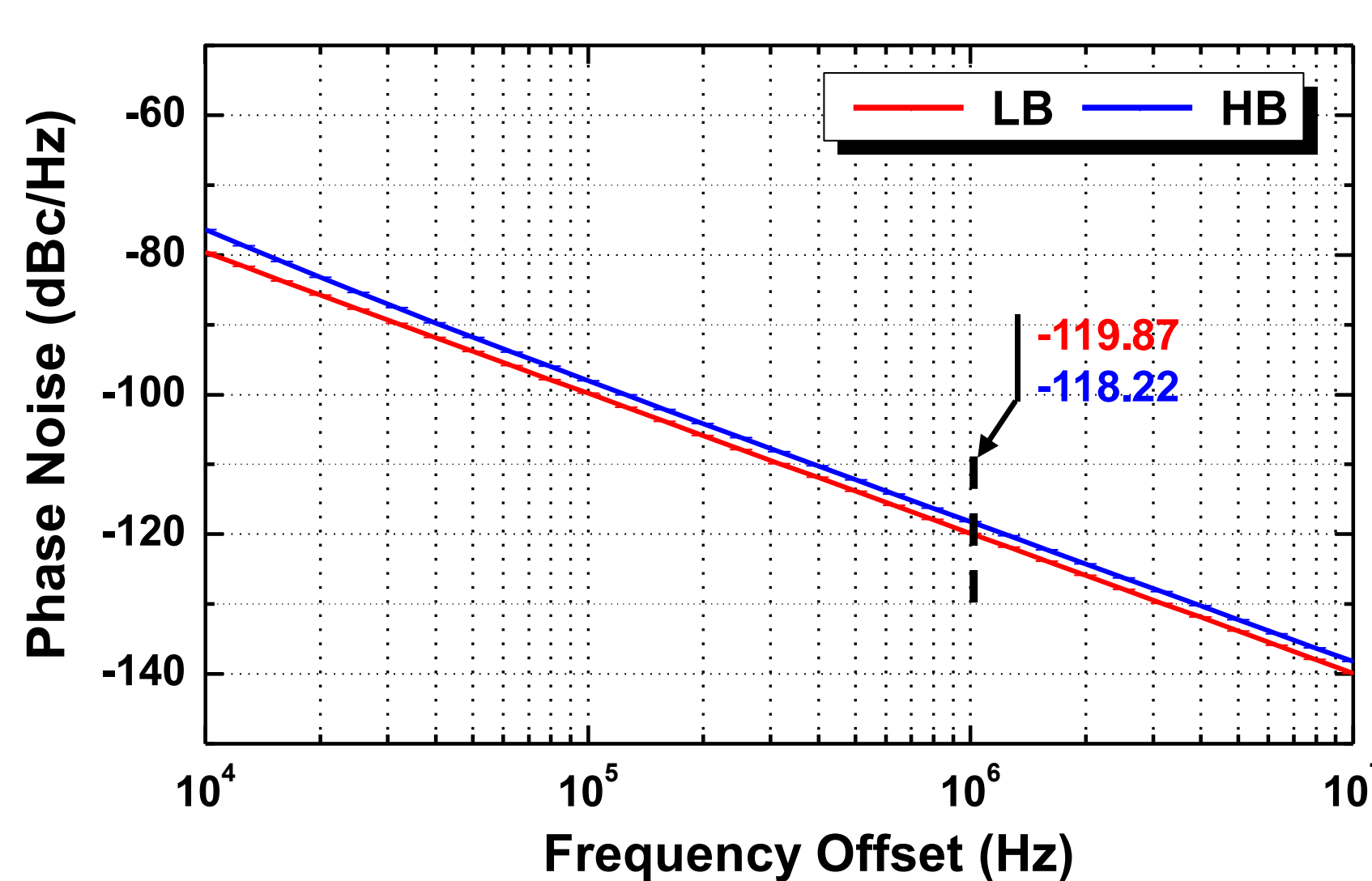

[Phase Noise]

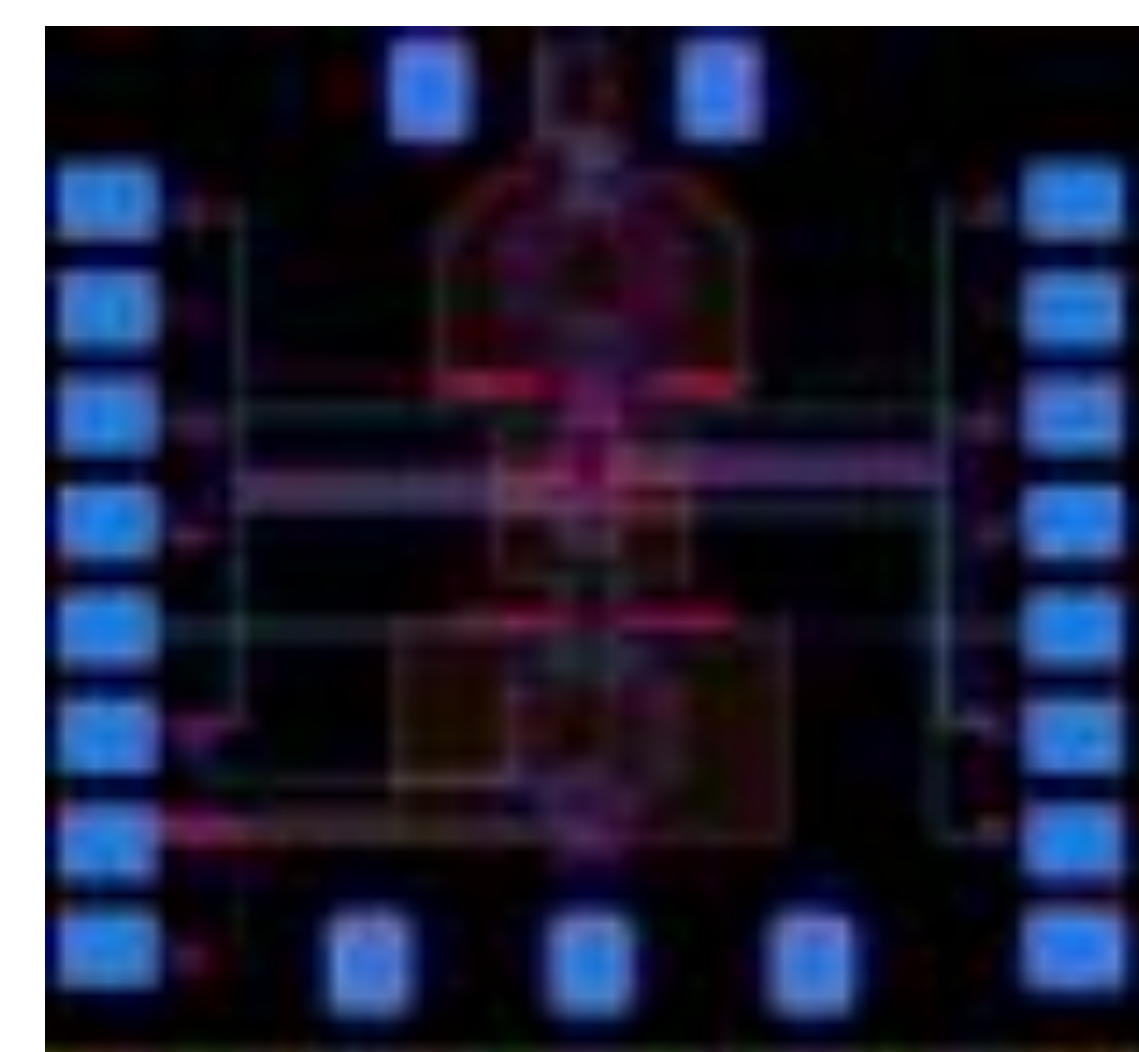

[Chip Layout of the designed VCO]

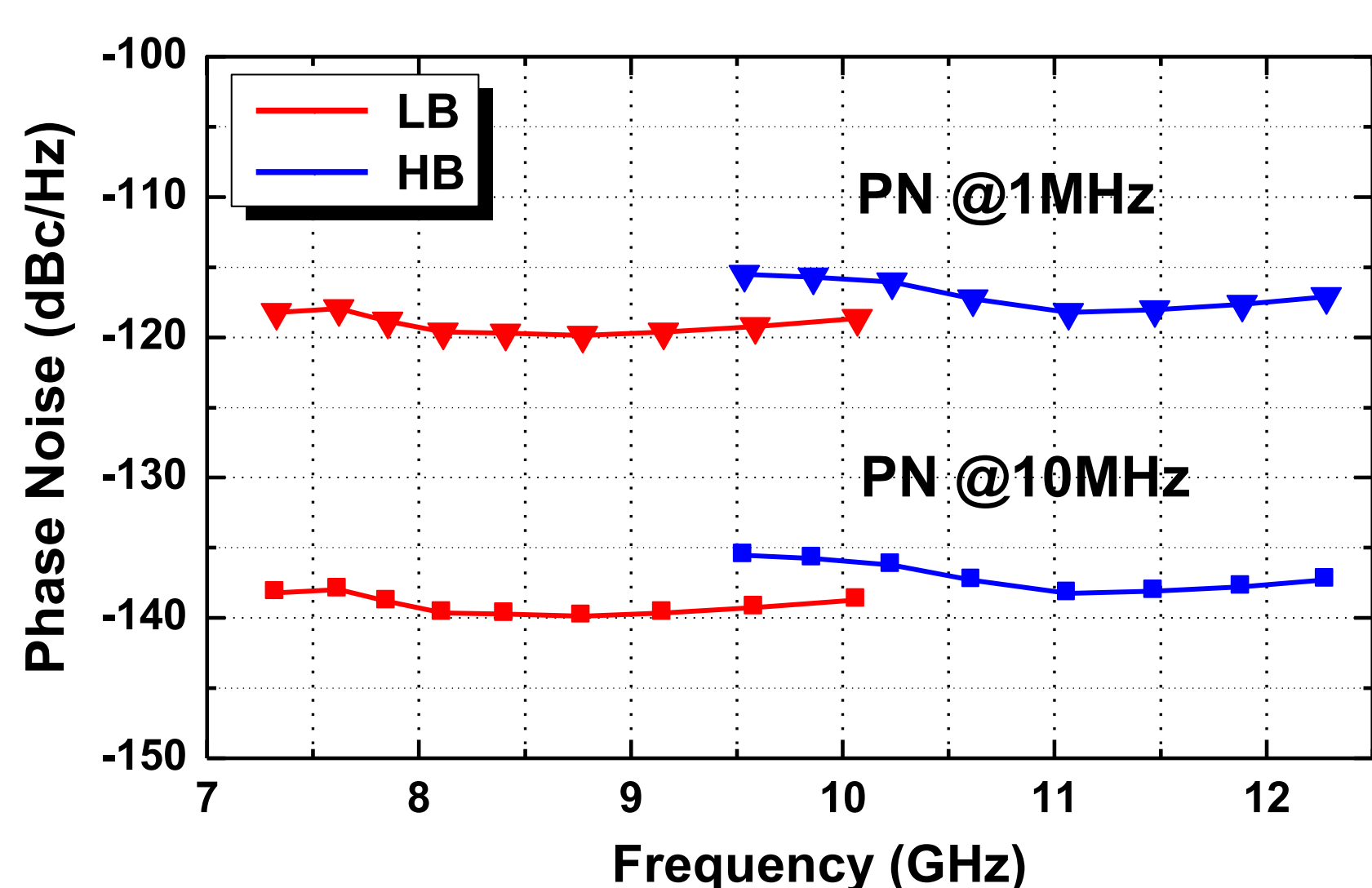

[Phase Noise Versus Frequency]

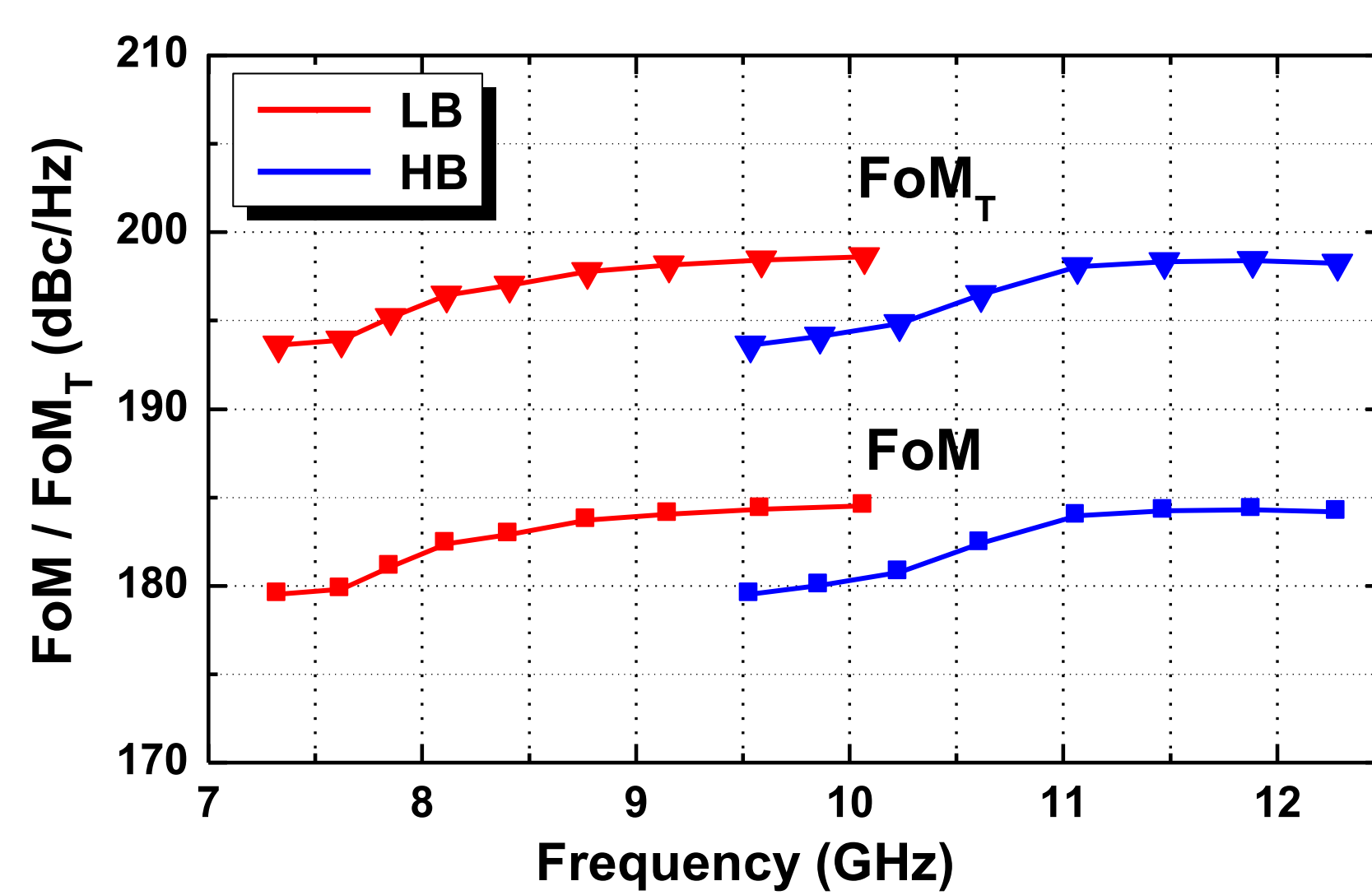

[FoM & FoM_T Versus Frequency]

Conclusion

- A Dual-core VCO using switched inductor
Compact implementation with dual-band operation
- Designed a CMOS VCO covering the FR3 band
 - PN @1MHz : -119.87 to -115.53 dBc/Hz
 - PN @10MHz : -139.88 to -135.55 dBc/Hz
 - FoM @1MHz : 179.53 to 184.53 dBc/Hz
 - Frequency range : 7.33 to 12.28 GHz (50.5% tuning range)

The chip fabrication and EDA tool were supported by the IC Design Education Center(IDECE), Korea.